

RETAIL WEIGHING SOLUTION™

CAS Millennium 2000 series

Weighing & Counting Scale

As a simple weighing scale with a maximum of 1/15,000 resolution, Millennium 2000 is suitable in a variety of industrial environments, including traditional market, with its low body and ergonomics design.

Easy Grab Body



Rear Display



USB Port



High Resolution for Weighing (Max. 1/15,000, Certificate 1/3)

Easy Grab Body

USB Port for COMM. & Power

Rear Display for Customer

Scan with your smartphone
to find more products



CAS

www.globalcas.com

Millennium 2000

Weighing & Counting Scale



Feature

- High Resolution for Weighing (Max. 1/15,000, Certificate 1/3,000 dual)
- Easy Grab Body
 - Ergonomics design with a low body and comfortable handling



- USB Port for COMM. & Power (Option)



- Rear Display for Customer (Option)



- Rechargeable Battery (Option)
 - A maximum of 1,000 hours when used with Mn or Pb battery together

Option

- RS-232 (Print, Command)
- Rear Display
- Rechargeable Battery & Adaptor
- USB Port
- SUS Tray

Application

- Open market, Farm, Industrial Environment

Specifications

MODEL	Millennium-06	Millennium -15	Millennium-30
Capacity	6kg	15kg	30kg
e (Non-Certi.)	1g, 0.5g, 0.2g	2g, 1g, 0.5g	5g, 2g, 1g
e (Certi.)	1/2(g) Dual	2/5(g) Dual	5/10(g) Dual
Resolution	1/3,000 - 1/15,000 Dual Interval, Certi. (1/3000-1/15,000)		
Display	6Digit LCD (115x39.5mm) & Back light (White)		
Symbols	STABLE, ZERO, TARE, g, kg, lb, oz, PCS, Low Battery HI/OK/LO&PCS		
Functions	Hold, Unit Conversion, Counting-Counting Sample Range: 10-100, 200, 300, 400, 500 Weight Comparison Function: HI, OK, Low, Sleep Mode Function		
Operation Time	Approx. D size Battery = 500hr Or Pb Battery = 450hr (Backlight off)		
Option	RS-232 (Print, Command), Rear Display Rechargeable Battery and Adaptor, USB Port, SUS Tray		
Power	Mn (500hr), Pb (500hr), Mn + Pb (1000hr)		
Dimensions	245 (W) x 280(D) x 110(H)		
Platter Size	225(W) x 190 (D)		
Product Weight	2.44 kg		

DIMENSION

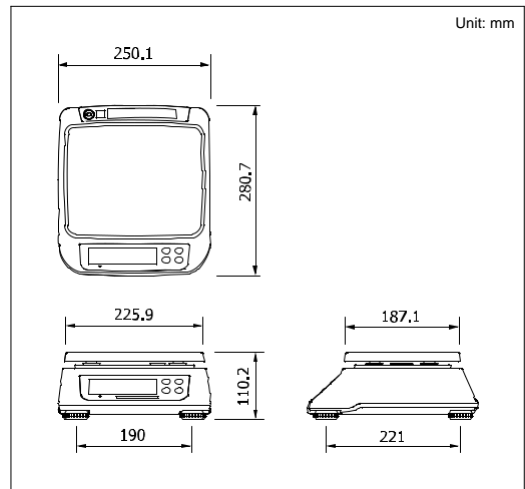

CAS BLDG., 1315, YANGJAE-DAERO,
GANGDONG-GU, SEOUL, KOREA

TEL_ 82 2 2225 3500
FAX_ 82 2 475 4668

Specifications are subject to change without notice improvement



CAS

<http://www.globalcas.com>