



● Recommended maximum platform size:

PA6340:300mmx300mm

PA6340A:500mmx700mm

STANDARD CAPACITY :

5, 10, 15, 20, 30, 50, 100, 150, 200 lb

5, 10, 15, 20, 25, 30, 50, 60, 100, 200 kg

WIRING:

RED +INPUT GREEN +OUTPUT

BLACK -INPUT WHITE -OUTPUT

4 COLOR SHIELD CABLE 5FT(1.5m)

● Specifications

Rated output	2.0mV/V±10%
Accuracy class	0.03
Non-linearity	0.03% F·S
Hysteretic	0.03% F·S
Non-repeatability	0.02% F·S
Creep in 30 minutes	0.03% F·S
Temperature effect span	15 PPM /°C of Applied Load
Temperature effect zero	26 PPM /°C of Applied Load
Compensated temperature range	-10°C~40°C
Operating temperature range	-40°C~65°C
Zero balance	±1% F·S
Input resistance	400±15 Ω
Output resistance	350±3 Ω
Safe overload	150%F·S
Ultimate overload	300%F·S
Excitation voltage	10VAC/DC
Maximum excitation voltage	15VAC/DC
Insulation resistance	≥5000M Ω (50V DC)
Environmental protection	IP67
Material	Aluminum

※All specifications are a maximum as a%(±) of full load, otherwise stated.

PA6340

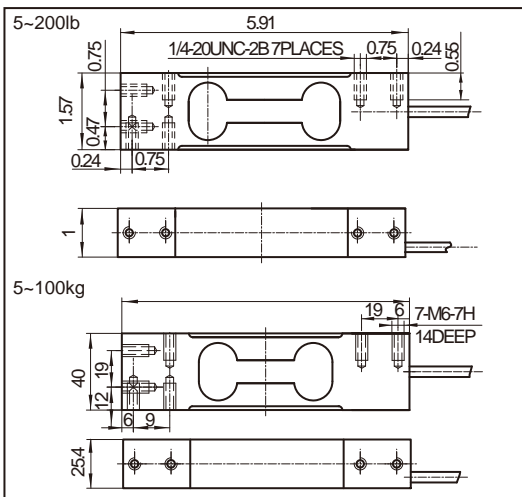

PA6340A

