

RW Weighing Indicator

General Specifications

- Display 22mm digit LCD display, with white LED backlight
- Keyboard 6keys(Mechanical switch)
- Housing ABS plastic
- Max. Divisions 6,000e; 30,000d
- Load cell excitation voltage 5V/150mA
- ADC update $\leq 1/10$ second
- Operate Temp $-10^{\circ}\text{C} \sim +40^{\circ}\text{C}$
- Power AC adapter (12V/500mA), optional Ni-MH batteries (1.2V/2000mAh x 6)

- Gross weight 1kg
- Packing Master carton 8 in 1 packing, dimension 0.073 m^3 , 40 feet container can load 5600 machine, 20 feet container can load 2800 machine



- An economical general purpose instrument
- Application: 1. Check weighing 2. Net/gross shift 3. Weighing units conversion
- OIML approval from Delta(approval no.:DK0199.284)
- Battery provide up to 40 hours of continuous use (without backlight)
- Standard RS-232 can connect to a mini printer, label printer or computer



RW Weighing Indicator

Model Number	Capacity	Readability	Division	Approx. weight	Approval
RW	X	X	30,000d	1kg	CE
RW-M	X	X	6,000e	1kg	CE,OIML

Options



Dimensions(mm)

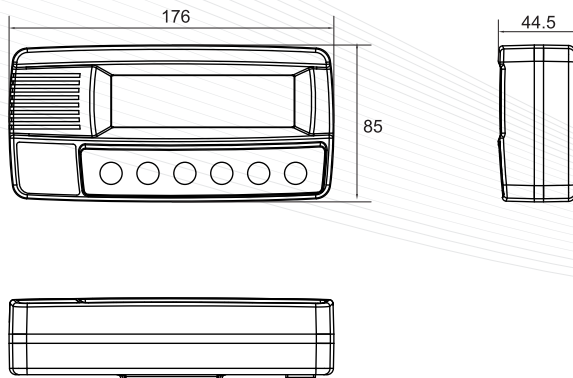

Print formats

